

Stump Grinder, Light Duty

Operator's Guide

1. *Stump Grinding Tips*- This machine is designed to do light duty grinding on stumps that are no more than 10" in diameter. You can expect to shave off about 1/2"-1" per sweep. Keep in mind that softer woods, like pine or fir, will sweep easier than hardwoods, like cherry, maple or oak. These differences, as well as the width and height of the stump, will effect the amount of time it will take to complete your job. For best results, it is recommended to first cut or trim the stump with a power saw, to level the stump and to get it as low to the ground as possible.

2. *Before you Start*- Dig away the earth and remove any stones near the tree stump that may interfere with your work. Check the ground to make sure it is free of foreign objects, such as electric cables, wires, etc. **Do not** use this machine on grades of more than 10 degrees. **Do not** allow the blade to touch the ground until it has stopped turning. **Do not** allow the cutting wheel to be too low on the stump, which may cause the machine to "climb" over the stump and become unstable.

3. *Stump Grinding*- Place the cutting blade near the top front edge of the tree stump. Set the brake to lock position. Set the throttle to SLOW (Start) DISENGAGE. Set engine switch on handlebar to ON. Tilt the machine on its wheels, lifting the cutting wheel off the ground. Hold the dead man's grip bar and start the engine. **Allow the machine to warm up for two minutes at idle before grinding.** Set the throttle to FAST to engage clutch. Place the middle of the cutting wheel approximately 1" above and 3/4" to 1 1/2" into the stump. Place the cutting wheel in the upper front edge of the stump. Swing the cutting wheel from side to side while lowering it about one inch after each pass until the front edge of the stump is gone. Before moving the machine forward, you should be sure that the cutting wheel is above the ground and located on either side of the stump. Move the machine forward by releasing the brake, pushing it forward, activating the brake again. Repeat the previous steps until the upper portion of the stump has been removed. **Do not** cut deeper than ground level at this stage. Set the throttle to SLOW (Start) DISENGAGE and wait for the cutting wheel to stop rotating. Release the brake and pull the machine away from the stump.

4. *Stump Grinding (below ground level)*- When you are finished the above steps, clear the area of wood chips around the stump. Adjust the handle position to achieve a better hand and arm work position. Pull the handle control lever and adjust the handle to the desired position. Repeat steps in #3 until you reached desired depth. Shut off machine when you are done.

Main components and operating controls

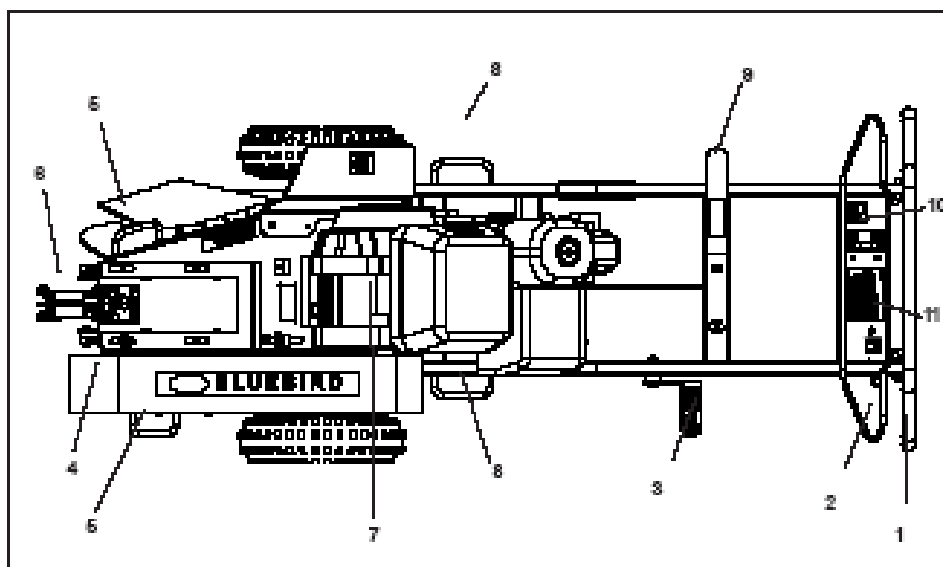

- | | |
|------------------------------------|----------------------------------|
| 1. Handle | 7. Engine |
| 2. Dead man's grip bar | 8. Rear lifting handle |
| 3. Brake lever | 9. Adjustment bar for the handle |
| 4. Belt guard for the cutter drive | 10. Throttle |
| 5. Front lifting handle | 11. Engine switch |
| 6. Cutting wheel | |

Engine

Exterior engine components and controls.

- | |
|---|
| 1. Throttle |
| 2. Starter |
| 3. Starter handle |
| 4. Fuel valve |
| 5. Choke control |
| 6. Air filter |
| 7. Spark plug |
| 8. Muffler |
| 9. Oil dipstick |
| 10. Oil drainage |
| 11. Oil level guard |
| 12. Engine switch - disconnected use switch on handle bar |
| 13. Fuel tank |
| 14. Fuel filler cap |

